



Single-phase insertion energy meter up to 60 A

- Up to 60 A
- Direct insertion connection method
- ModBUS-RTU Protocol
- LCD's Display

KET-PMM-311

Applications

Monitoring consumption

The **KET-PMM-311** is a new-generation, single-phase, direct-input electricity meter for installation on low-voltage systems. The device, equipped with an LCD display, incorporates measurement, statistics and communication functions, among others. Advantages from which the meter can benefit include, for example, high stability, low power consumption and data storage after a power failure. All meters fulfil the technical requirements for electronic power meters in the IEC62053-21, IEC62053-22 standards. Features **ModBUS-RTU** protocol with RS485 interface to meet network management requirements.

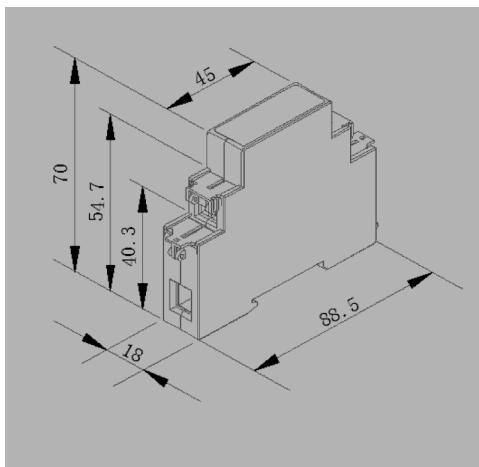

Technical Features

General specifications	Protection Range: IP20 Operative Temperature: -25 ÷ +55 °C Storage Temperature: -40 ÷ +70 °C Relative Humidity: MAX 95% not condensing
Case	Dimensions: 18 x 96 x 70 mm (W x H x D) Mounting: DIN-rail Required DIN modules: 1 DIN module
Power supply	Supply Voltage: 230 VAC (50 Hz) Consumption: Self-consumption <10 VA Connectors types: Integrated screw terminals
Power meter	Insertion Types: 1-phase 2-wire Connection: Direct measurement Maximum Rated Current: 10(60) A Accuracy: 1 Class Connections: Screw connectors <4.0 Nm Supported Protocols: ModBUS RTU Communication Rate: 38400, 19200, 9600, 4800 bps Isolation: Class II Connectors types: Integrated screw terminals Current Inputs: 80 A
Certifications	Referends Standard: IEC62053-21, IEC62053-22