



Presence, temperature and light environmental sensor with ModBUS interface

KET-TLP-110

Applications

Versius

KET-AIR-210

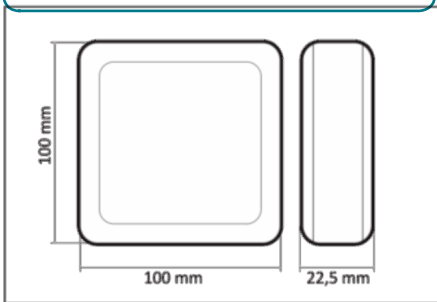

- Perfect integration into BEMS / BMS systems
- 12 VDC power supply
- Input for dry contact
- Suitable for wall or ceiling mounting

KET-TLP-110 is an environmental sensor capable of detecting the movement of people within a radius of about 3-4 meters. The built-in **double light sensor** allows you to limit the lighting of lights only below a certain lighting threshold that can be set remotely. The temperature sensor completes the characteristics of the device.

The **ModBUS** interface allows the connection of the KET-TLP-110 to **SCADA** systems, programmable logic and standard monitoring systems.

The dry contact input can be used for connecting door / window contacts, PIR sensors or control buttons.

Designed to easily integrate into energy supervision and management systems (BMS / BEMS).

Technical Features

General specifications	Protection Range: IP40 Operative Temperature: -10 ÷ +60 °C Storage Temperature: -15 ÷ +60 °C Relative Humidity: MAX 80% not condensing
Case	Dimensions: 100 x 100 x 22.5 mm (W x H x D) Mounting: Wall mounted with supplied plate Material: ABS, self extinguishing: UL 94 V-0
Power supply	Supply Voltage: 5 ÷ 12 VDC Connectors types: Removable spring clamps
Rs485 interface	Supported Protocols: ModBUS RTU Slave Communication Rate: 9.6, 19.2, 38.4 o 57.6 Kpbs Connectors types: Removable spring clamps
Digital inputs	Channels: 1 for dry contact with detection time at contact variation of about 50ms.
Functionality	Output Power Adjustment: From remote Firmware Upgrade: Via USB C connector Support for public environment: Anti-removal support, keyboard lock
Temperature sensor	Sensor Type: NTC or digital (Only .TH version) Measure Range: -40 ÷ +123.8 °C Precision: ±0.4 ÷ 25 °C Repeatability: ±0.1 °C Resolution: ±0.01 °C
Humidity sensor	Version: Only .TH version Measure Range: 0 ÷ 100%RH Precision: ±3%RH from 20 to 80%RH Repeatability: ±0.1%RH Resolution: ±0.03%RH Hysteresis: ±1%RH Long Period Stability: <0.5%RH/year
Light sensor	Number of sensors: 2, on front and on top Measure Range: 10 ÷ 1000 Lux Response Curve: Similar to that of the human eye
Motion sensor	Measurand: Up to 4 m; Recommended 0 ÷ 3.5 m Viewing Angle: <=100° cone angle, distance <=4m