



# ModBUS Gateway with universal interface for all HVAC systems; Daikin VRV version

## KET-CCL-135.DAI

### Applications

Thermoregulation

### Versius

KET-RMB-211.CN.35

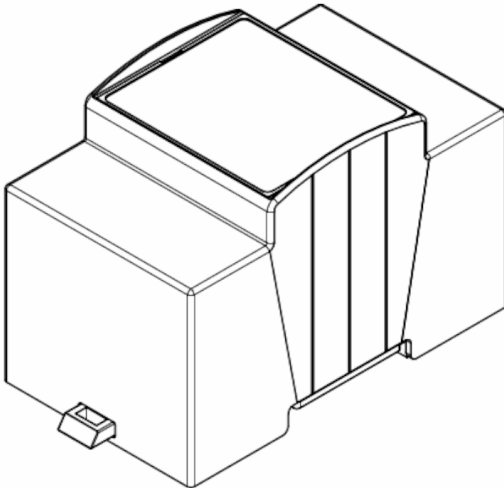

- Unified Climate ModBus Map (UCLIM) - same ModBUS addresses and registers for every brand (Daikin, Mitsubishi, etc.)
- Zero Configuration - immediate integration without studying proprietary protocols
- Industrial Performance - Instantaneous Response and Comprehensive Diagnostics in Real Time.

### Technical Features

|                        |  |
|------------------------|--|
| General specifications | <b>Protection Range:</b> IP30<br><b>Operative Temperature:</b> -10 ÷ +60 °C  |
| Case                   | <b>Dimensions:</b> 53.5 x 90.5 x 61 mm (L x H x D)<br><b>Mounting:</b> The DIN rail<br><b>Required DIN modules:</b> 3 DIN modules<br><b>Electric Board Type:</b> Industrial or consumer unit<br><b>Material:</b> Blend PC/ABS self-extinguishing UL94-V0   |
| Power supply           | <b>Supply Voltage:</b> 12 ÷ 48 VDC/AC<br><b>Consumption:</b> 370 mA<br><b>Connectors types:</b> Pluggable spring terminal blocks   |
| Datalogger function    | <b>Memory Type:</b> F-RAM: parameter storage in case of power loss   |
| Rs485 interface        | <b>Channels:</b> 1 Master and 1 Slave<br><b>Supported Protocols:</b> ModBUS RTU Slave to the PLC and ModBUS RTU Master to the HVAC control unit<br><b>Communication Rate:</b> 9600 to 38400 bps; default set to 38400 bps<br><b>Isolation:</b> Isolated<br><b>Connectors types:</b> Pluggable spring terminal blocks |
| Digital inputs         | <b>Channels:</b> 4 digital inputs for dry contact (Max. 30 Hz)   |
| Relé' outputs          | <b>Channels:</b> 4 SPDT relay digital outputs with NC C NO changeover contact<br><b>Maximum Switching Voltage:</b> 250 VAC, 24 VDC<br><b>Maximum Rated Current:</b> 8 A<br><b>Max. Inrush Peak Currents:</b> High-Inrush Model: Peak current up to 100 A<br><b>Isolation:</b> 1,000 MOhm min @ 500 VDC               |
| Certifications         | <b>Approvals:</b> CE   |
| Compatibility          | <b>Control Unit:</b> Daikin Modbus Interface DIII EKMBDXB7V1<br><b>Brand:</b> Daikin<br><b>Controlled Units:</b> VRV Indoor Units  |